

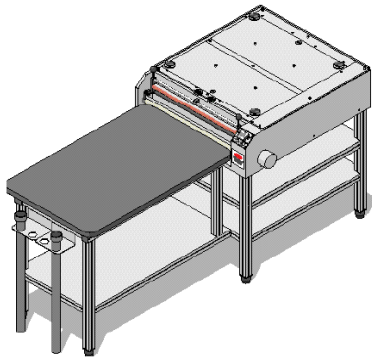

Case Study: Product Development Color Versatility Unit



A large chemical company participating in the pre-print proofing market needed a custom color versatility unit developed to enhance their existing product portfolio. PEKO engineered and developed a complete commercialized solution from an existing "bread board" concept within 6 months. With a full agency approved production launch occurring within a year through the use of our internal manufacturing capabilities. PEKO provides the full contract manufacturing with shipments directly to the clients end-user customers.

